

IoT Based Glucose Level Monitoring

K. Prasad Babu¹, Syed Noorullah², K. Saraswathi³, K. Siri⁴, B.Lakshmi⁵

¹Associate Professor, Dept of ECE, Ashoka Womens Engineering College, Affiliated to JNTUA, Anantapuramu,

²Assistant Professor, Dept of ECE, Ashoka Womens Engineering College, Affiliated to JNTUA, Anantapuramu

³Assistant Professor, Dept of ECE, Ashoka Womens Engineering College, Affiliated to JNTUA, Anantapuramu

⁴192T1A0454, Dept of ECE, Ashoka Womens Engineering College, Affiliated to JNTUA, Anantapuramu

⁵192T1A0414, Dept of ECE, Ashoka Womens Engineering College, Affiliated to JNTUA, Anantapuramu

Abstract

The expanded usage of portable advances and splendid contraptions in the region of medical services has caused uncommon impact on the world. In this project we look at about the system that is planned to screen the glucose level of the person. By making the data available in cloud, it will in general be used by the experts to get the chronicled data. This structure is executed by using the NodeMCU for getting data, a power supply is used which takes in DC input, we have used ESP8266 Wi-Fi chip which is related with the NodeMCU which goes probably as the data transmission unit over a framework and besides goes probably as a central processor for tolerating and sending the data. The NodeMCU is related over a base board and a voltage regulator is also used to thwart the damages in case of high voltage. We have used IR sensor for social affair the data and moving it to NodeMCU and with the help of Wi-Fi accessibility we can move the data to our figuring devices and can be appeared over screen. It is the place where we assemble the data without taking blood tests anyway using IR sensor which go IR radiates through the veins and tissues of the body and accumulates the information. This information is moved to the chip for change of data to units with the objective that it very well may be appeared over a PC screen. By and by the data to be shown is assembled over a web application which gives cloud-based limit and moreover gives contraptions which help in showing data over the web application. This web application helps in get-together information from the gear and show it to us. The third contraption is a light which turns itself on when the examining crosses the fundamental line. We can set the base and most prominent by modifying the devices according to our need. And for the diabetes prediction, we are using machine-learning to perform the task. This project helps in identifying whether a patient is at risk of having type-2 diabetes or not. In this project, K-NN algorithm was used for classification of the Pima Indian diabetes database.

Keywords: IoT, COMATOSE PATIENTS, Glucose level monitoring.

1. Introduction

Coma is the most widely observed condition on Earth that may eventually cause passing if appropriate human administrations are not present. Long-term problems result from disease control failure, which also have an effect on the patients' quality of life. If the patient's glucose level is monitored daily, it will assist them in managing their health effectively. The patient can regulate their prosperity gradually with the use of facts about their sugar level this will help better human administrations the leading group of their patients. This structure is executed by using the Node-MCU for scrutinizing data from the customer and is a non-prominent procedure. It is the place where we accumulate the data without taking blood tests yet using IR sensor which sends IR

radiates through veins and assembles the data. Here we are using Thing Speak web application through which are delivering the data into actual units and can be watched and taken apart for extra examinations. This web application helps in gathering information from the hardware and show it to us. This web application has gad gets which shows every one of the sections and data accumulating. Another gad gets which is a gauss type meter which shows the proportion of blood glucose level present in the body. The third gadget is a light which turns itself on when the glucose level crosses the fundamental line. We can set the base and most prominent by changing the devices as by our need. Finally we incorporated a temperature sensor which helps in observing internal heat level and help the patient work .The

associated wellbeing which alludes to any high-level medical services frameworks plan that can work distantly, with additional pieces of constant wellbeing noticing, crisis acknowledgment and can alarm limits. They have using WBAN arrange for accessibility, which is not capable to make readings for adaptable sensors. The WBAN is flaw by wired framework limit between the body advancements. It is absence of mix sensors. Prior there were systems which give blood glucose level by taking blood tests and subsequently giving the report. It was an extended methodology where the patient necessities to keep believing that their reports will be disseminated by the scientific concentrations yet these days by the extension in advancement and equipment, we can get data inside no time. Here by this strategy, we spare the hour of patient by giving there ports quickly and cost capably. We have presented an IOT based medical care noticing approach to manage comatose. It is a self-organization with the goal of treatment, moving the accentuation from a standard clinician-focused way to deal with a patient cantered one. The principle commitment of this work is the new plan and headway of a phase to help another multidimensional philosophy for comatose patients care. The Associated medical care which permits to any high level advanced medical care game plan that can work distantly, with additional fragments of reliable wellbeing noticing, emergency recognition and can caution people. They have using WBAN arrange for accessibility, which is not gainful to make readings for convenient sensors. The WBAN is flaw by wired framework constraint between the body advancements. There is absence of Integration sensors. Prior there were frameworks which give blood glucose level by taking blood tests and afterward giving the report yet these days by the expansion in innovation and gadgets we can get information with non-intrusive strategies. Testing your glucose level is likely the best ways to deal with oversee esteem your comatose and how different kind of food, drugs, and activities impact comatose. Watching your blood glucose can support you and your fundamental idea expert makes a game plan to manage this condition. People use conservative blood glucose estimating gadget, called glucose

meters, to check their glucose levels. These work by reviewing an unobtrusive proportion of blood, as a last resort from a fingertip yet we have used an alternate methodology where a lancet cautiously pricks your skin to get the blood. Meters let you know your present glucose. In any case, since glucose levels change, you need to test levels as routinely as could sensibly be anticipated and record them. You can discuss the expense with your essential consideration, a doctor or medication subject matter expert. Glucose meters go with testing strips, little needles, or lancets, top rick your finger, and contraption to hold the needle. The unit may join a logbook, or you may have the choice to download the readings onto your PC. Meters contrast in cost and size. Some have added feature features out different necessities. These may include: Audio capacities with regard stop with vision handicap, screens to backlist screens to help you with seeing the minor lowlight, additional memory or data or preloaded test strips for people who experience using their hands. This is a truly non- intrusive checking gadget that rapidly surveys and shows an individual's blood glucose level in about a second without patients' finger being pricking or any torture. Non-Obtrusive system includes an IR sensor that gets to the finger and measures the customer's glucose level using imaginative and endorsed sensor drives. The glucose results are managed in the contraption and used to survey HbA1c level using a prohibitive assessment. The contraption can in like manner show glucose regards graphically, enamoring the customer to check glucose levels after some time. Web of Things (IOT) is a strategy of actual devices that has ability to move the data without human. This could be or cause a blunder on the exactness of the forecast of comatose. Regardless of whether delivering incorrectly results for a patient. To change these qualities to make significance full lines so information is by tracking down theme an of that section and entering it in them is-entered cells for better exactness and productivity. The changed qualities can be anything condition, for example, mean, standard deviation and so forth. There can likewise be repetitive information in the dataset that has not been considered, which ought to be changed or taken out from the dataset.

These outcomes have been confirmed by fusing the disarray lattice to check for the genuine positives, genuine negatives, bogus positives, and bogus negatives. The outcome tosses the precision of every one of these mode is on both the preparation information and the test information.

2. Objectives

Current glucose checking strategies for the consistently growing number of comatose individuals all over are meddlesome, anguishing, dull, and a solid burden for the family cash related cut-off. The non-nosy glucose watching improvement beats these confinements, for which this point is overall being examined and addresses a stimulating and astoundingly looked for after pitch for specific affiliations. This survey intends to offer a forefront report on the standard degrees of progress for non-intrusive (NI) and insignificantly unmistakable (MI) glucose watching sensors, gadgets right now accessible on the lookout, administrative design for precision evaluation, new advances toward right now under magnifying glass by administrator parties and trained professionals, and assessment types for signal improvement and worth longing. The outline in like way examines the future illustration of glucose region by investigating the use of the various social affairs in the electromagnetic reach. The investigation understands that the distribution and use of new headways for glucose ID is unavoidable and closer to change into a reality.

3. Methods

If the glucose level is checked bit by bit, it will help the patient with dealing with their prosperity properly. The info information regarding the in sugar level is valuable for the patient to manage the prosperity step by step. In this protect we inspect about the system that is proposed to screen the glucose level of the person. By making the data available in cloud, it will in general be used by the experts to get the valid data. This will help better restorative administrations the chiefs of their patients. This structure is executed by using the Node MCU for scrutinizing data from the customer and is a non-prominent method. It is the place where we accumulate the data without taking blood tests anyway using IR sensor which

sends IR radiates through veins and assembles the data. Here we are using Think Speak web application through which are making the data into actual units and can be watched and explored for extra assessments. This web application helps in get-together information from the hardware and shows it to us. This web application has gadgets which show every one of the areas and data accumulating. Another gadget which is a gauss type meter which shows the proportion of blood glucose level present in the body. The third gadget is a light which turns itself on when the scrutinizing crosses the fundamental line. We can set the base and generally outrageous by changing the devices as shown by our need. Finally, we incorporated a temperature sensor which helps in observing internal heat level and helps the patient work on it. The Connected wellbeing which alludes to any high-level medical services frameworks game plan that can work distantly, with additional pieces of constant wellbeing noticing, crisis acknowledgment and can alarm limits. They have using WBAN coordinate or accessibility, which isn't capable to make readings for adaptable sensors. The WBAN is flaw by wired framework constraint between the body improvements. It is absence of combination sensors. Prior there were systems which give blood glucose level by taking blood tests and a short time later giving the report. It was an extended strategy where the patient requirements to keep believing that their reports will be appropriated by the insightful concentrations yet these days by the development in advancement and equipment, we can get data inside no time. Here by this strategy, we spare the hour of patient by giving the reports promptly and cost capably. These qualities are simple in beginning however are changed over to computerized signals utilizing hub MCU. The Power supply is associated with the fundamental board through 12v +GND supply with the opposite end on UI GND supply. The information beneficiary is associated through a 5V GND supply which is on the primary board and that provisions current through VCC yield on the information getting end while the data is moved through the D0 yield pin. This is the means by which information is sent through preposterous. We have utilized three modules in the model. One is the information

beneficiary for example IR gadget for glucose estimation. Second is the information transmitter for example the NODE MCU. Third is the force supply. Information transmitters comprise of a base board for associating the Wi-Fi module, it likewise trades the simple current data to advanced signs which are appeared to the product that will be an electronic application which tells the measure of blood glucose level in the blood we are utilizing Thing Speak web application for gathering, putting away and understanding information. Here we just need to sign in utilizing

the email and a secret key. We have utilized think talk since it is extremely basic and give a ton of utilizations to understanding information and putting away information. Here we are putting away the information on the cloud. To see the information, we use gadgets and with the assistance of it we get the exact estimations. One gadget is utilized as a gauss meter and the other gadget is utilized for graphical portrayal of information. We have likewise presented alight which shows itself on when the glucose level is estimated and is above ordinary imprint.

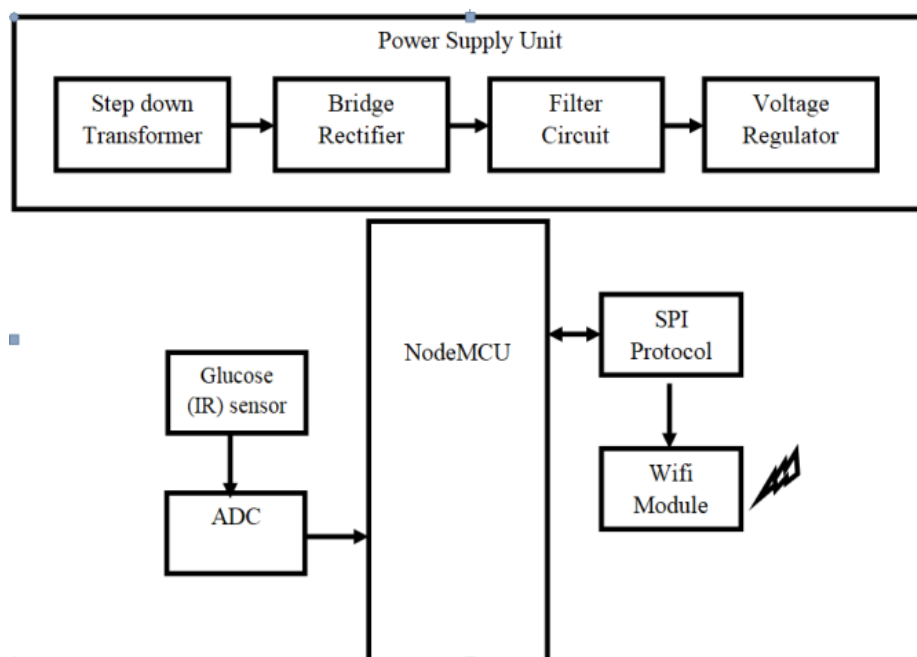

Figure: Block Diagram of proposed design.

4. Results

In the training phase, this algorithm only stocks the data set but when the new data is available, then the data is classified into different types that are very similar to the new data.

Step 1: The first step consists of the deployment of interconnected devices including sensors, actuators, monitors, detectors, camera systems, etc. These devices collect the data.

Step 2: Usually, data received from sensors and other devices are in analog form, which needs to

be aggregated and converted to the digital form for further data processing.

Step 3: Once the data is digitized and aggregated, this is pre-processed, standardized and moved to the data center or cloud.

Step 4: Final data is managed and analyzed at the required level. Advanced Analytics, applied to this data, brings actionable business insights for effective decision-making.

Different Test Cases With Their Obtained Outcomes

Table 1 Test Cases Status

TEST CASEID	TEST DESCRIPTION	STEP DETAILS	EXPECTED RESULT	ACTUAL RESULT	STATUS
1	To ensure if data is being correctly mapped to the data frame	We check if the data frame contains data or not	The assertion is to be True as the data frame does contains the importedData	The data is presentation the data frame.	Pass
2	Check for are any null values/empty spaces present in data set	Check for any null values/empty spaces in the table	The assertion must return False asthere aren'tany empty spaces in he Data frame	The assertion returns True	Fail
3	Check the glucose level showed by the device	Check whether the glucose is normal or abnormal	The assertion must return value up to150 for females and160formale	The assertion returned is normal,provingth e135	Pass
4	Check if the patient has taken meal within two hours before testing	Check we a there glucose is normal or abnormal	The assertion must return value which can be 30points up the normal mark	The assertion returns normal providingthevalue as160	Pass
5	Check if the accuracy rate for training is more than60%	Check if the accuracy rate algorithm training is more than60%	The assertion must return True, as the accuracy expected is more than60%	The assertion returned is True as the accuracy rate is more than 60%	Pass
6	Check if the accuracy rate for testing is more than60%	Check if the accuracy rate for algorithm testing ismorethan60%	The assertion must return True, as the accuracy expected is more than60%	The asertion returned is True as the accuracy rate is more than 60%	Pass

5. Discussion

Coma is perhaps the most constant and the biggest developing illness in India. We can in far that a superior strategy for expectation of comatose is this non obtrusive technique. This technique gives us a nine act out come after the parting and investigation of the preparation and testing information. The proficiency of this strategy is great when contrasted with the obtrusive technique. Data Samples for this system were procured from the blood glucose checking structure and were assessed. It communicates that the data tests how a deflection of 4 to 5 units for each finger change and the data assessed can be

logically following two hours of banquet. The review in like manner discusses the future example of glucose acknowledgment by looking at the use of the different gatherings in the electromagnetic range. The study presumes that the allocation and usage of new headways for glucose is proof is unavoidable and closer to transform into a reality. To make effective diagnosis, it is important to discover the knowledge from data sets. The very aim of machine is to extract every bit of information that is stored in dataset and get an output. Here, this project aim sat discovering a model to predict diabetes in females. Pre-processing is used to improve the data quality in

the dataset. During pre-processing, many attributes of the dataset are considered to predict diabetes. The algorithm which we used for classification in the project gives out maximum accuracy when compared to these classification algorithms. Finally, the result is stored in Jupiter Note book currently, but can be handed in the future by creating a web page and connecting it using Flask to show the result in it.

Current glucose checking strategies for the ever-expanding number of diabetic individuals around the globe is intrusive, difficult, tedious, and a steady weight for the family unit spending plan. The non-obtrusive glucose observing innovation beats these constraints, for which this subject is fundamentally being looked into and speaks to an energizing and exceptionally looked for reseller's exchange for some organizations. This audit intends to offer a modern report on the main advances for non-obtrusive (NI) and negligibly intrusive (MI) glucose observing sensors, gadgets as of now accessible in the market, administrative system for exactness evaluation, new methodologies right now under investigation by and calculation types for signal improvement and worth expectation. The audit likewise talks about the future pattern of glucose recognition by dissecting the utilization of the various groups in the electromagnetic range. The survey presumes that the selection and utilization of new advancements for glucose location is unavoidable and closer to turn into a reality. Coming to this project, this system can be designed for some other prediction of some other disease such as lung diseases, thyroid, etc. Other enhancement that can be done is if somehow the number of attributes can be reduced for prediction. Taking in less numbers of attributes and producing more accurate results with them would be a great enhancement.

References

- [1] Lorem ipsum dolor sit amet, consectetur adipiscing elit, sed do eiusmod tempor incididunt ut labore et dolore magna aliqua.
- [2] Ipsum dolor sit amet consectetur adipiscing elit pellentesque.
- [3] Orci eu lobortis elementum nibh. Faucibus a pellentesque sit amet porttitor.
- [4] Egestas tellus rutrum tellus pellentesque eu tincidunt tortor. Sagittis orci a scelerisque purus semper eget. Vitae purus faucibus ornare suspendisse sed nisi lacus sed viverra.
- [5] Augue interdum velit euismod in pellentesque massa placerat duis ultricies. Metus aliquam eleifend mi in nulla posuere sollicitudin aliquam ultrices.
- [6] Velit laoreet id donec ultrices tincidunt arcu non sodales neque. Non curabitur gravida arcu ac tortor dignissim convallis aenean et.